

**Model:  
S2505  
J1812  
F2901**

---

**OWNER'S MANUAL**

*MX2™* CONTROL EQUIPPED

WOOD PELLET BURNING HEATER

\* INSTALLATION \* OPERATION \* SERVICE \* PARTS \*

**Model S2505 & Insert**



**J1812 ® & Insert**



**F2901**



---

**CAUTION:**

Read all instructions carefully before starting the installation or operating the heater. Failure to follow these instructions could result in property damage, bodily injury or even death. Contact local building or fire officials about restrictions and installation inspection requirements in your area. Save this manual for future reference.

Manufactured By:  
APR Industries Ltd.  
1354 Waverley Street  
Winnipeg, Manitoba, R3T 0P5  
Canada

Printed in Canada  
Rev Nov 2008

[www.pelletstove.ca](http://www.pelletstove.ca)



CAUTION: Stove has moving parts.  
Disconnect power before servicing.

Please contact your local building officials (i.e. municipal building department, fire department, fire prevention bureau, etc.) to determine the need to obtain a permit.

# Table Of Contents

<b>I. SAFETY FIRST!!!</b> .....	<b>4</b>
<b>II. INSTALLATION</b> .....	<b>6</b>
<b>1. Clearance to Combustibles</b> .....	<b>6</b>
1.1 Installation Clearances .....	6
1.2 Other Clearances and Recommendations .....	8
<b>2. Electrical Requirements</b> .....	<b>9</b>
<b>3. Fuel Requirements</b> .....	<b>9</b>
3.1 Physical Properties .....	9
3.2 Fuel Storage .....	9
<b>4. Location of the Heater</b> .....	<b>10</b>
<b>5. Typical Installation Configurations</b> .....	<b>10</b>
<b>6. Venting System</b> .....	<b>11</b>
6.1 Exhaust Vent Pipe Requirements .....	11
6.2 Exhaust Vent Termination Requirements .....	13
6.3 Combustion Air Intake Requirements .....	14
<b>7. KOZI Pellet Insert Additional Considerations</b> .....	<b>15</b>
7.1 KOZI Pellet Insert Additional Requirements .....	15
7.2 Surround Assembly .....	16
7.3 KOZI Pellet Insert Installation .....	16
7.4 KOZI Pellet Insert Removal .....	17
7.5 Operation and Maintenance .....	17
<b>8. Mobile Home Additional Installation Requirements</b> .....	<b>17</b>
8.1 Typical Mobile Home Installation Configuration .....	17
8.2 Recommendations for Mobile Home Installation .....	18
8.3 Mobile Home Combustion Air Intake Requirements .....	18
8.4 Exhaust Vent Requirements .....	19
8.5 Other Mobile Home Installation Requirements .....	19
<b>III. OPERATION</b> .....	<b>20</b>
<b>1. General overview</b> .....	<b>20</b>
<b>2. Safety features</b> .....	<b>20</b>
<b>3. Electric Igniter</b> .....	<b>20</b>
<b>4. MX2TM Control</b> .....	<b>20</b>
4.1 Basic Description .....	20
4.2 "AUTO,HIGH/LOW,MANUAL" Switch .....	20
4.3 "ON/OFF" Button .....	22
4.4 "HEAT SELECT" Button & Bar Graph .....	22
4.5 "AUGER" Button .....	22
4.6 "FAN" Button .....	22
4.7 "TRIM" Button .....	22
4.8 Wall thermostat, wall switch or other switching device. ....	23
4.9 Damper Control .....	23
4.10 Starting (lighting) your Heater for the First Time .....	23
4.11 Starting (lighting) your Heater .....	24
4.12 Stopping your Heater .....	25
4.13 Adjusting your Heater .....	25
<b>IV. MAINTENANCE &amp; CLEANING</b> .....	<b>25</b>
<b>V. TROUBLE SHOOTING GUIDE</b> .....	<b>30</b>
<b>1. Trouble Shooting</b> .....	<b>30</b>
<b>2. Corrective Actions</b> .....	<b>31</b>
2.1 Proof Of Flame Failure .....	31
2.2 Pressure Switch Failure .....	31
2.3 Manual Reset Thermal Disk Failure .....	32
2.4 Ignition Failure .....	32
2.5 Overheating .....	32
2.6 Lack of Air. ....	32
2.7 Excess air. ....	33
<b>VI. DIAGRAMS AND PARTS LIST</b> .....	<b>34</b>
<b>1. KOZI MX2TM Control Circuit Diagram</b> .....	<b>34</b>
<b>2. Stove Cross Section</b> .....	<b>35</b>
<b>3. Equipment Compartment</b> .....	<b>36</b>
<b>4. Parts List</b> .....	<b>37</b>
<b>VII. WARRANTY</b> .....	<b>37</b>
<b>WARRANTY CARD / ONLINE REGISTRATION</b> .....	<b>39</b>

## **I. SAFETY FIRST!!!**

This heater is suitable for both mobile home and conventional home installation. Read all instructions carefully before starting installation. Save this manual for future reference.

1. Read these instructions carefully. Failure to follow them could cause a malfunction of the heater, damage to the heater, property damage, bodily injury or even death.
2. Familiarize yourself with the heater's operation. (See "Operation" section)  
If you are not sure, ask your dealer for explanations on your heater's proper operation.
3. The burn pot of this heater is designed for premium grade wood pellets. Pellets with too much fines and saw dust must be screened before use. **DO NOT USE WET PELLETS.** Refer to the "Fuel Requirements" section for more information.
4. Oil the circulation fan motor bearings every 6 months. See "Maintenance" section for more details.
5. Check your local building codes regarding restrictions or installation requirements. All installations must comply with local building codes.
6. This heater requires a floor protector beneath the heater and extending a minimum of 6 inches (150mm) in front and beyond each side of the fuel loading and ash removal openings of the heater. This is to catch any spillage, which may occur during opening and closing of the doors. See figure 1 for more information.
7. Use only UL/ULC listed Type PL or Type L venting for the exhaust system. This heater is designed for use with 3-inch (76 mm) vent pipe. Avoid long runs and too many bends. It may be necessary to increase the size of the vent pipe to 4 inch (102 mm) if long runs and too many bends are unavoidable. See "Venting System" section for more information.
8. Combustion of wood pellet fuel leaves ash in the heater and venting system. These ashes must be removed from the heater and venting regularly (approximately once a week, more frequently for high ash content fuels). See "Maintenance" section for more information. The entire system must also be cleaned at the start of each heating season. A yearly inspection of the venting is highly recommended.

9. The heater must be turned off and allowed to cool before cleaning. Make sure there are no hot ashes or embers present. Use a brush and scoop to clean. Only use vacuum cleaners specifically designed for use with hot ashes. Place all ashes in a sealed metal container with a tight fitting lid.
10. Store all pellet fuel at a safe distance (at least 36 inches / 1 meter) away from the heater and in a sealed metal container. DO NOT place the fuel within the installation clearances of the stove or within the space needed for ash removal and start up.
11. This heater is POWER VENTED. The vent pipes have positive pressure during operation. It is IMPERATIVE that all joints in the venting system be SEALED to prevent any leakage of exhaust gases inside the house. All joints must be sealed using high temperature silicone sealer (RTV). Aluminum tape is not an adequate sealant.
12. Use of outside combustion air is highly recommended and is mandatory in mobile home installations. Connect the air intake of the heater to the exterior of the building with a noncombustible metal pipe with a minimum diameter of 2 inches (50 mm) (Use APR Part No AK100). Use of plastic pipe is not permitted.
13. This appliance is wired and grounded according to the CSA C22.1 code for Canada and the NFPA 70 code for the USA. Also, this heater meets the fuel burning appliance installation codes NFPA 211 in the USA and CSA B365 in Canada.
14. Do NOT operate the heater with the door open. Make sure the door and any other opening in the stove are closed tightly during operation. Inspect the gaskets of the door and other openings periodically to make sure they are in good condition.
15. Replace broken or defective components only with parts provided by the manufacturer. See WWW.KOZISTOVES.COM or contact your local dealer to find out how to purchase replacement parts.
16. Follow this manual carefully for proper installation. If you are uncertain, call your dealer. Most dealers have qualified and trained installers. We highly recommend the use of their services.

## II. INSTALLATION

### 1. Clearance to Combustibles

#### 1.1 Installation Clearances

Please refer to the following figures for all clearances to combustibles. Please note that these clearances are for your **KØZI** heater only. Each venting manufacturer/supplier has their individual clearances which must also be respected.

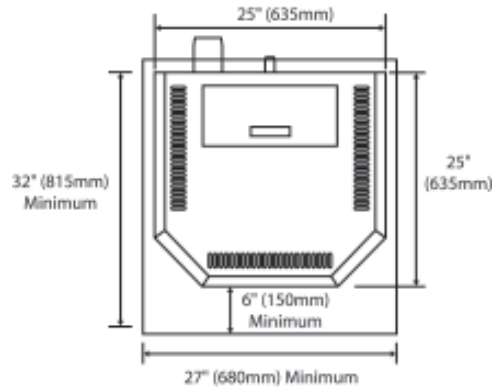

Figure 1. **KØZI** BayWin noncombustible floor protector (same dimensions apply to Model 100 and KSH Series).

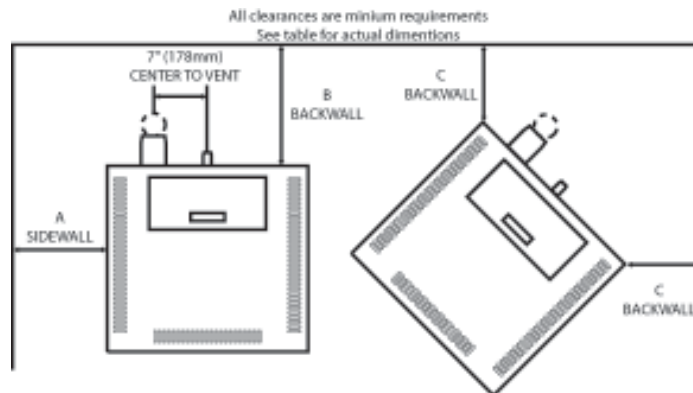

Figure 2. Sidewall Clearances

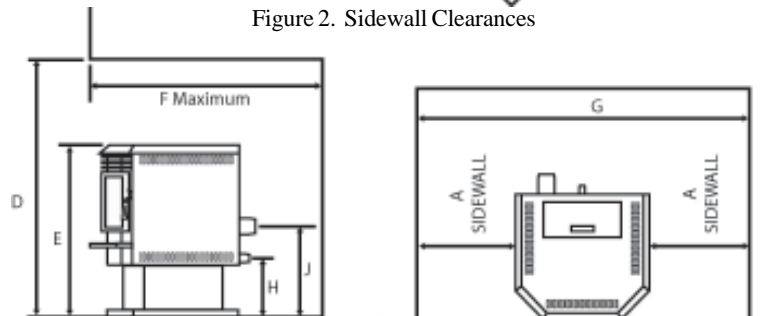

Figure 3. Alcove Clearances

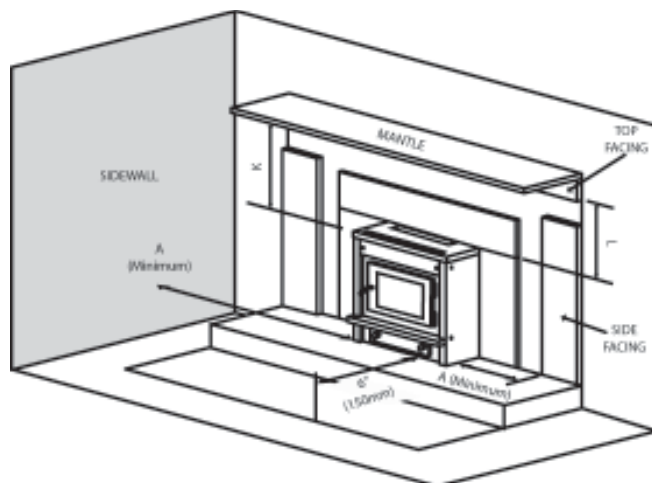

Figure 4. Insert Clearances

INSTALLATION COMMENT: We recommend sufficient space be provided (minimum 20 inches/500 mm) on each side of the heater to service the equipment area. If this is not possible, a provision must be made to pull the heater out for service.

All dimensions are minimum dimensions unless marked.						
Dimension	Description	BayWin	Model 100	KSH Series	BayWin Insert	Model 100 Insert
A	Unit to side wall or side facing	12" (300 mm)	5" (125 mm)		12" (300 mm)	5" (125 mm)
B	Unit to back wall	1" (25 mm)			N/A	
C	Corner of unit to wall	1" (25 mm)			N/A	
D	Alcove height	48" (1220 mm)			38" (965 mm)	
E	Overall unit height	30.5" (775 mm)		30.5" (775 mm)*	21.25" (540 mm)	
F	Alcove depth (Maximum)	30" (760 mm)				
G	Alcove width	48" (1220 mm)	34" (865 mm)		48" (1220 mm)	
H	Floor to centerline air intake	11" (280 mm)		3" (75 mm)	1.5" (38 mm)	
J	Floor to centerline exhaust	18" (458 mm)		10" (255 mm)	8.5" (215 mm)	
K	Unit to mantle	N/A			13" (330 mm)	
L	Unit to top facing	N/A			13" (330 mm)	
* Overall unit height with 200lbs hopper extension is 39" (990 mm).						
* Overall unit height with 280 lbs hopper extension is 47" (1195 mm).						

Table 1. Clearance Dimensions

Additional installation information can be found in the "Typical Installation Configurations" section and your venting manufacturer/supplier's literature.

INSTALL VENT AT CLEARANCES SPECIFIED BY THE VENT MANUFACTURER

## 1.2 Other Clearances and Recommendations

1. This heater must be mounted on a noncombustible material, placed underneath the heater and extending a minimum of 6 inches (150 mm) in front and beyond each side of the fuel loading and ash removal openings of the heater.
2. Clearances can ONLY be reduced by means approved by local building or fire officials in your area.
3. A safety certification label has been attached to either the back of the heater or on top of the hopper (inserts). A sample label is shown here to help you locate this label on your heater. Please read all information on your heater's label. All information on the certification label supersedes any information contained in this manual.



**Warnock Hersey**  
C W US

**LISTED ROOM HEATER, PELLETIZED FUEL TYPE**  
ALSO FOR USE IN MOBILE HOMES  
APPAREIL DE CHAUFFAGE RÉPÉTOIRÉ, À COMBUSTIBLE EN  
GRANULES PEUT ÊTRE UTILISÉ DANS UNE MAISON MOBILE

DO NOT REMOVE THIS LABEL.  
NE PAS ENLEVER CETTE ÉTIQUETTE

SER. NO. / NO. DE SÉRIE: 1001-  
NO. DE SÉRIE: 1001-

MODEL / MODÈLE: KOZI BAYWIN REPORT NO. / NO. DE RAPPORT: 476-1123 (MAR. / MARS, / 06)  
TESTED TO / ÉPROUVÉ POUR RÉPONDRE AUX NORMES: UL - 1482 / UL-907 / ULC - S627 / ULC - S625 / ASTM-E 1939 / WH-PM-025.

THIS PELLET FIRED APPLIANCE HAS BEEN TESTED AND LISTED FOR USE IN MANUFACTURED HOMES IN ACCORDANCE WITH CANADIAN ADMINISTRATIVE RULES B14.25-008 THROUGH 009.  
CET APPAREIL DE CHAUFFAGE À GRANULES A ÉTÉ ÉPROUVÉ ET RÉPÉTOIRÉ POUR UNE UTILISATION DANS LES MAISONS CONSTRUITES CONFORMÉMENT AUX RÈGLES ADMINISTRATIVES DE L'ORDONNÉE NOB. 914-25-008 À 009.

INPUT RATING: 4.5 LBS. / HR. BURNING ELECTRONIC 120 V. 60 HZ. LESS THAN 4 AMPS  
ELECTRICAL RATING: 120 V. 60 HZ. LESS THAN 4 AMPS  
INSTALL AND USE ONLY IN ACCORDANCE WITH THE MANUFACTURER'S INSTALLATION AND OPERATION INSTRUCTIONS. SEE LOCAL BUILDING CODE AND MANUFACTURER'S INSTRUCTIONS FOR PRECAUTIONS REQUIRED FOR PASSING VENT COMPONENTS THROUGH A COMBUSTIBLE WALL OR CEILING. CONTACT LOCAL BUILDERS OR FIRE OFFICIALS ABOUT RESTRICTIONS AND INSTALLATION INSPECTION IN YOUR AREA. DO NOT CONNECT THIS UNIT TO A CHIMNEY FLUE SERVING ANOTHER APPLIANCE.  
PUSSEMENT NOMINAL: 4.5 LBS. / HR. BORNÉES ÉLECTRIQUES: 120V. 60HZ. MOINS DE 4 AMPS  
INSTALLER ET UTILISER L'APPAREIL CONFORMÉMENT AUX INSTRUCTIONS D'INSTALLATION ET DE FONCTIONNEMENT DU FABRICANT. CONSULTER LE CODE LOCAL OU BÂTIMENT ET LES INSTRUCTIONS DU FABRICANT AFIN DE CONNAÎTRE LES PRÉCAUTIONS EXIGÉES POUR L'INSTALLATION DES RACCORDS D'ÉVENT DANS UN MUR OU UN PLAFOND COMBUSTIBLE. CONSULTER AVEC LES AUTORITÉS LOCALES EN MATIÈRE DE BÂTIMENT ET DE LUTTE CONTRE LES INCENDIES POUR CONNAÎTRE LES RESTRICTIONS ET LES HORRES D'INSPECTION DES INSTALLATIONS DANS VOTRE RÉGION. NE PAS RACCORDER À UN TUYAU DE TRAVAIL DÉSIGNANT UN AUTRE APPAREIL.

**MINIMUM CLEARANCES TO COMBUSTIBLE CONSTRUCTION - INSTALLED AS A FREESTANDING STOVE**

A. SIDEWALL TO UNIT - 12" / 305 mm  
B. BACKWALL TO UNIT - 1" / 25 mm  
C. CORNER TO UNIT - 1" / 25 mm  
MIN. ALCOVE WIDTH - 40" / 1020 mm  
MIN. ALCOVE HEIGHT - 40" / 1020 mm  
MAX. ALCOVE DEPTH - 30" / 760 mm



COMBUSTIBLE FLOOR MUST BE PROTECTED BY A NON-COMBUSTIBLE MATERIAL EXTENDING TO THE FRONT (D - 4" / 100 mm) AS SHOWN.

**MINIMUM CLEARANCES TO COMBUSTIBLE CONSTRUCTION - INSTALLED AS AN INSERT OR HEARTH MOUNTED STOVE FOR USE WITH MASONRY OR LISTED FACTORY-BUILT FIREPLACES.**

D. FLOOR PROTECTOR - 6" / 150 mm  
E. SIDEWALL TO UNIT - 12" / 305 mm  
F. MANTLE TO UNIT - 13" / 330 mm  
G. TOP FACING TO UNIT - 13" / 330 mm  
H. SIDE FACING TO UNIT - 12" / 305 mm



FOR USE WITH PELLETIZED 1/4" OR 5/16" DIA. SOLID WOOD FUELS ONLY. DO NOT BURN COAL. OPERATE ONLY WITH VIEWING DOOR AND ASH REMOVAL DOORS CLOSED. REPLACE GLASS ONLY WITH CERAMIC GLASS. COMPONENTS REQUIRED FOR INSTALLATION: 3" / 75 mm DIAMETER LISTED TYPE L OR TYPE PL VENT, OUTSIDE COMBUSTION AIR INLET. FOR INSERT AND HEARTH MOUNT INSTALLATION, A LISTED SINGLE WALL CHIMNEY LINER MUST BE USED.

**LIGHTING INSTRUCTIONS:**  
TURN SWITCH TO "ON". PLACE A SMALL AMOUNT OF PELLETS AND FIRESTARTER ON GRATE AND IGNITE. TIGHTLY CLOSE VIEWING DOOR AND TURN FUEL FEED TO MEDIUM. WHEN FIRE IS BURNING WELL, ADJUST FEED AND FAN CONTROLS AS NECESSARY.

**SHUTDOWN INSTRUCTIONS:** TURN FUEL FEED OFF. TURN SWITCH TO "OFF"

**DÉGAGEMENTS MINIMUM DES ÉLÉMENTS DE CONSTRUCTION COMBUSTIBLES - INSTALLATION COMME POËLE NON ENCASTRÉ**

A. ENTRE L'APPAREIL ET LE MUR LATÉRAL - 12 PO / 305 mm  
B. ENTRE L'APPAREIL ET LE MUR ARRIÈRE - 1 PO / 25 mm  
C. ENTRE L'APPAREIL ET LES CORNS - 1 PO / 25 mm  
LARGEUR MIN. DE L'ALCOVE - 40 PO / 1020 mm  
HAUTEUR MIN. DE L'ALCOVE - 40 PO / 1020 mm  
PROFONDEUR MAX. DE L'ALCOVE - 30 PO / 760 mm

LE PLANCHER COMBUSTIBLE DOIT ÊTRE RECOUVERT D'UN MATÉRIAU NON COMBUSTIBLE À L'AVANT DE L'APPAREIL (DISTANCE 0-4 PO/100 mm TEL QU'ILLUSTRE).

**DÉGAGEMENTS MINIMUM DES ÉLÉMENTS DE CONSTRUCTION COMBUSTIBLES - INSTALLATION COMME APPAREIL ENCASTRÉ OU SUR UN ÂTRE DANS UN OUVRAGE DE MAÇONNERIE OU DANS UN FOYER RÉPÉTOIRÉ ET MONTÉ EN USINE.**

D. RECOUVERTURE DU PLANCHER - 6 PO / 150 mm  
E. ENTRE L'APPAREIL ET LE MUR LATÉRAL - 12 PO / 305 mm  
F. ENTRE L'APPAREIL ET LE MANTREAU DE LA CHIMNÉE - 13 PO / 330 mm  
G. ENTRE L'APPAREIL ET LE PARAPET SUPÉRIEUR - 13 PO / 330 mm  
H. ENTRE L'APPAREIL ET LE PARAPET LATÉRAL - 12 PO / 305 mm

UTILISER QUE DES GRANULES DE COMBUSTIBLE SOLIDE AU BOIS DE 1/4 PO DE DIAMÈTRE. NE PAS BRÛLER DE CHARBON. FERMER LES PORTES D'OBSERVATION ET D'ÉVACUATION DES CENDRES AVANT DE FAIRE FONCTIONNER L'APPAREIL. NE REMPLACER LE VERRRE QU'AVEC DE VERRRE CÉRAMIQUE. ÉLÉMENTS REQUIS POUR L'INSTALLATION: ÉVENT RÉPÉTOIRÉ DE TYPE L OU PL DE 3 PO / 75 mm DE DIAMÈTRE, PRISE D'AIR DE COMBUSTION EXTÉRIEURE. SI L'APPAREIL EST ENCASTRÉ OU INSTALLÉ SUR UN ÂTRE, IL FAUT INSTALLER UNE DOUBLURE DE CHIMNÉE RÉPÉTOIRÉE POUR MUR SIMPLE.

**INSTRUCTIONS DE MISE À FEU:**  
BASCULER L'INTERRUPTEUR EN POSITION "MARCHÉ". PLACER UNE PETITE QUANTITÉ DE GRANULES ET DE PRODUIT DE MISE À FEU SUR LA GRILLE ET ALLUMER. FERMER SÈREMENT LA PORTE D'OBSERVATION ET RÉGLER L'ALIMENTATION EN COMBUSTIBLE À LA POSITION MOYENNE. LORSQUE L'APPAREIL CHAUFFE ADÉQUATEMENT, RÉGLER L'ALIMENTATION ET LE VENTILATEUR AU BESOIN.

**POUR FERMER L'APPAREIL:** COUPER L'ALIMENTATION ET BASCULER L'INTERRUPTEUR EN POSITION ARRÊT.

**CAUTION**



NOT WHILE IN OPERATION. DO NOT TOUCH. KEEP CHILDREN, CLOTHING AND FURNITURE AWAY. CONTACT MAY CAUSE SKIN BURNS. SEE NAMEPLATE AND INSTRUCTIONS.

MADE IN CANADA BY: APR INDUSTRIES LTD.  
FABRIQUÉ AU CANADA PAR: WINNEPES, MAN.

**MISE EN GARDE**

L'APPAREIL DEVIENT CHAUD LORSQU'IL FONCTIONNE. NE PAS TOUCHER. ÉLOIGNER LES ENFANTS, LES VÊTEMENTS ET LES MEUBLES DE L'APPAREIL. TOUT CONTACT PEUT ENTRAÎNER DES BRÛLURES. CONSULTER LA PLAQUE D'IDENTIFICATION ET LES INSTRUCTIONS.

Figure 5 Certification Label



**2. Electrical Requirements**

1. This heater is an electrical appliance. The North American versions of this appliance require 120 Volts, 60 cycle and 3 Amps of electrical power. The European versions of this appliance require 230 Volts, 50 cycles and 2 Amps of electrical power. All heaters with an electric igniter require an additional 300 watts of electrical power during the start up sequence.
2. The heater comes with a 5 ft. (1.5 M) long, grounded, electrical cord suitable to plug into any standard residential electrical outlet. The electrical outlet must be grounded.
3. When installed in mobile home, the heater must be grounded to the steel chassis of the home (unless this is not required by local code).

**3. Fuel Requirements**

**3.1 Physical Properties**

Your heater is very sensitive to fuel quality. Every effort should be made to use only the best pellet fuel available in your area. This heater is designed for premium grade, 1/4 inch (6.35 mm) or 5/16” (7.94mm) diameter wood pellets only. The following should assist you in selecting and using proper fuel.

<b><u>Good Fuel</u></b>	<b><u>Bad Fuel</u></b>
Made from hard or soft wood	Moist or wet
Dry	Lots of fines or sawdust
Clean	Longer than 1”
1/4” or 5/16” diameter	Contains binders (helps glue the fuel together)
1” or less in length	High ash content (greater than 1%)
Low ash (less than 1%)	Not made of wood

Burning any fuel other than wood pellets as described above will void your heater’s warranty and may void any insurance.

If you find your fuel has too much fines and saw dust, the fuel may be screened before use. DO NOT USE WET PELLETS under any circumstance. Longer fuel may cause bridging of the auger and result in erratic feeding or jamming. Fines, binders, ash, moisture will all cause your heater to plug up and not burn efficiently. “Poor” fuels require more frequent cleaning; the ashtray must be emptied and the burn pot must be cleaned on a weekly/possibly daily basis. Please refer to the “Maintenance” section for further instructions on cleaning your heater.

**3.2 Fuel Storage**

All pellet fuel should be stored in a clean dry place and at a safe distance (at least 36 inches / 1 meter) away from the heater. DO NOT place the fuel within the installation clearances of the heater or within the space needed for ash removal or starting of the heater.

#### 4. Location of the Heater

Before proceeding with the installation, the following sections should be reviewed:

- Section 4: Location of the Heater
- Section 5: Typical Installation Configurations
- Section 6: Venting System

When selecting a location for your new heater consider the following:

- a. Clearance to combustibles.
- b. Sufficient room to service the unit.
- c. Access for outside combustion air.
- d. NOT approved for bedroom installations
- d. Power within 5 feet (1.5 m).
- e. Access for exhaust venting.
- f. EVL not exceeding 25 ft. (7.6 m).
- See Exhaust Vent Requirements.

#### 5. Typical Installation Configurations

The following figures describe some typical installations. Variations of these are possible. Common sense, safety and compliance with local codes must be respected in any variation.

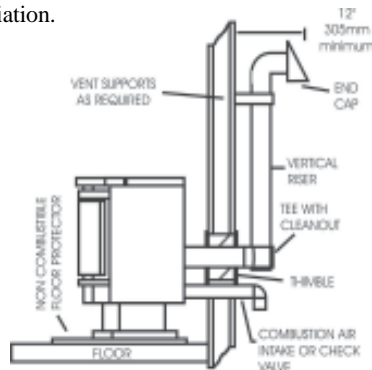
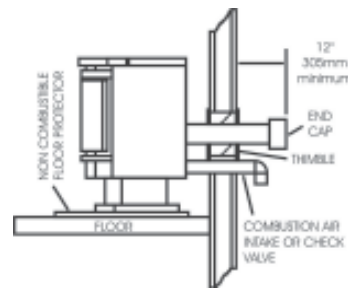

Figure 6. Free standing through the wall and up installation



(although this installation is permitted, a 3' (1 m) vertical rise is strongly recommended)

Figure 7 Free standing through the wall installation

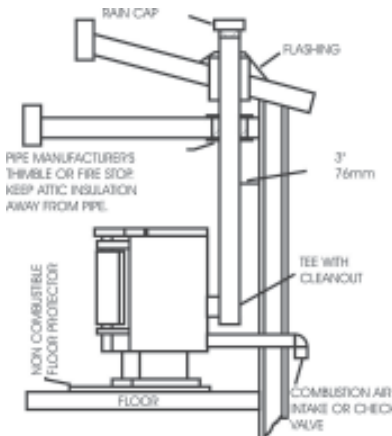

Figure 8. Free standing through the roof installation

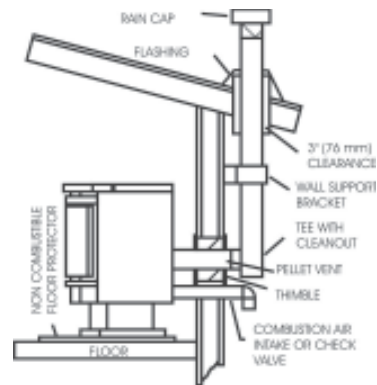

Figure 9. Free standing through the wall and the roof installation

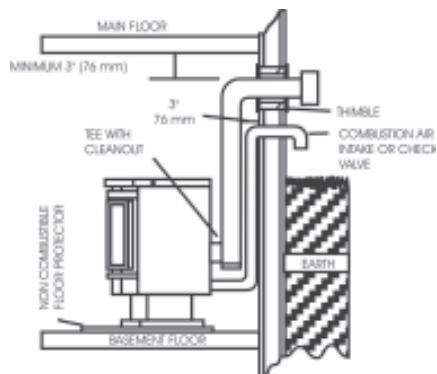

Figure 10. Free standing basement installation

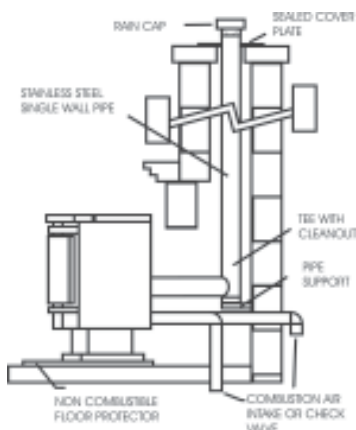

Figure 11. Free standing through a masonry chimney installation

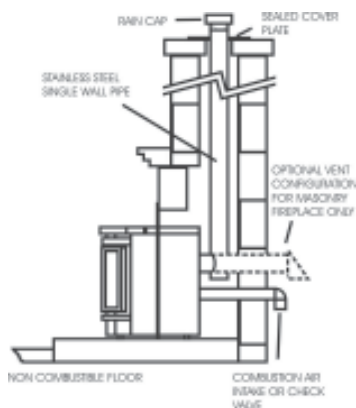

Figure 12. Factory built zero clearance or masonry fireplace insert installation

## **6. Venting System**

### **6.1 Exhaust Vent Pipe Requirements**

Your **KØZI** pellet heater works under negative pressure (vacuum). The exhaust fan of your stove pulls air from the air intake, through the stove and pushes it out the venting. As this air passes through the burn pot it is used to burn the pellets. Proper vent pipe sizing is very important to the proper operation of your stove. A proper size ULC/UL listed type PL or L venting should be used to provide the least resistance for movement of the combustion air.

Your **KØZI** pellet heater is certified for 3 and 4 inch exhaust venting. 3 inch venting is normally sufficient for most direct vent installations. Installations with several elbows, long horizontal and/or vertical runs may add too much resistance to air flow and may create burn problems. The use of 4 inch venting in these types of installations will reduce the possibility of burn problems. A simple technique called 'EQUIVALENT VENT LENGTH (EVL)' can be used to determine whether 3 or 4 inch vent pipe should be used.

To calculate EVL use the following formula:

for each 90° Elbow or T fitting	= add 5 EVL
for each 45° Elbow	= add 3 EVL
for each Horizontal run of vent	= add 1 EVL per foot of horizontal venting
for each Vertical run of vent	= add 1/2 EVL per foot of vertical venting

CAUTION: EVL CANNOT EXCEED 25 ft. (7.6 meters). Installations using an EVL exceeding 25 ft. (7.6 meters) are not permitted.

YOU MUST USE APPROPRIATE 4" VENTING IF:  
The EVL is 7 or more AND you are at or above an altitude of 3000 ft.  
OR  
The EVL is 15 or more  
OR  
Your heater is an Insert

If in doubt, use 4" venting. This will reduce the possibility of future burn problems.

DO NOT USE MAKESHIFT MATERIALS OR MAKE COMPROMISES IN THE INSTALLATION. IT IS A FIRE HAZARD.

DO NOT INSTALL A FLUE DAMPER IN THE EXHAUST VENTING SYSTEM OF THIS HEATER

DO NOT CONNECT THIS HEATER TO A CHIMNEY FLUE SERVING ANOTHER APPLIANCE

The vent pipes are on the exhaust side of the exhaust fan and are under pressure. Care must be taken to ensure that all the joints are completely sealed to prevent any leakage of exhaust fumes and smoke into the house. If you smell smoke, the venting has not been properly sealed. Use only high temperature RTV silicone for sealing. Aluminum tape is not considered an adequate sealant. At least 3 screws are needed for securing all vent pipe joints.

The venting of this heater is not allowed to pass through any closets, concealed spaces, floors, ceilings or attic spaces. If the venting must go through a wall or combustible partition, the installation must conform to the Installation Code for Solid Fuel Burning Appliance and Equipment CAN / CSA -B365. For more detailed venting information, please refer to your venting manufacturer's instructions.

### 6.2 Exhaust Vent Termination Requirements

1. It is highly recommended that the venting include a minimum 3' vertical rise before termination. This will help prevent any odor of smoke in the house during a power failure.
2. The exhaust vent must terminate into an open space. Under no circumstances is the vent allowed to terminate into closed or semi-closed spaces. Venting into a garage, under a sun deck, porch or any other space where the concentration of fumes may occur is prohibited.
3. The exhaust vent must be at least:
  - \* 4 feet (1.2 m) below
  - \* 4 feet (1.2 m) horizontally from
  - \* 1 foot (0.3m) aboveany opening in the building such as doors, windows, ventilation air intakes, etc.
4. The exhaust vent opening must be a minimum of:
  - \* 12 inches (0.3m) from the ground
  - \* 24 inches (0.61m) from any combustible surface i.e. fence, plant, etc.
  - \* 7 feet (2.1 m) from any public walkway
5. The exhaust air is EXTREMELY HOT. Caution must be taken to avoid contact with children, people, plants, animals, or any other object that may be affected by heat. It is recommended to use a vertical pipe to discharge the hot air at a safe elevation.
6. Vertical installations must have an approved vertical vent cap and horizontal installations must have an approved horizontal vent cap. Areas where severe wind conditions exist and vent caps are exposed to unprotected open areas additional protection (especially in horizontal installations) must be provided.

INSTALL ALL VENTING AT CLEARANCES  
SPECIFIED BY THE VENT MANUFACTURER

### 6.3 Combustion Air Intake Requirements

There are 2 methods of supplying the heater with combustion air. They are as follows:

1. Room Air: Conventional homes may use room air for combustion. Where room air is used, the exhaust pipe must incorporate a minimum 3' vertical section immediately adjoining the heater. It is highly recommended that the total exhaust vertical rise be longer than the total horizontal run and that the majority of the vertical rise be as close to the heater as possible..
2. Outside Air: All installations can be connected to the exterior of the building using a noncombustible metal pipe, with a minimum 2 inch (50mm) internal diameter or by using APR Part No: AK100 (Air Intake Kit). A larger diameter air intake pipe may be required if the length of intake exceeds 3' (1 meter) or has several bends. Use of plastic pipes are not permitted.

In some installations, outdoor combustion air may be needed to ensure proper performance. If your heater burns poorly, experiences roll-out or back-drafts, outside combustion air may be required.

The following restrictions apply to any and all installations:

1. Use of plastic pipes is not permitted under any circumstance.
2. The combustion air intake must terminate into a vented space, i.e. outside, vented attic, vented crawl space. This heater cannot draw air from a closed space such as a closed garage, airtight crawl space or any other sealed room.
3. The elevation of the combustion air intake must be below the exhaust vent. An elbow may be used to lower the air intake point below that of the exhaust vent.
4. Excessive lengths and elbows on the air intake pipe will cause airflow restrictions. A minimum of 2 inch (50 mm) or larger venting should be used for lengths exceeding 3' (1 meter). Increase the venting size as needed.
5. When installing a **KOZI** KSH 120 in a garage/work shop, the combustion air must be taken from the outside or else the unit must be elevated a minimum of 15 inches above floor level if inside combustion air is desired.

## **7. KOZI Pellet Insert Additional Considerations**

The **KOZI** Pellet Insert can be installed in either a masonry or listed factory built fireplace or an alcove. The minimum opening for masonry or listed factory built fireplace is pictured below. Please see the “Clearance to Combustibles” section for information on installing an insert in an alcove.

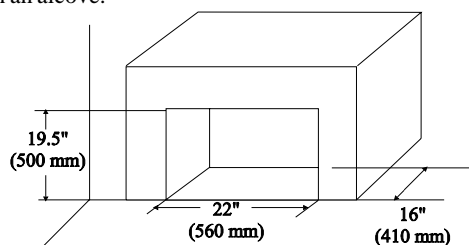

Figure 13. Minimum Fireplace opening for the **KOZI** pellet insert.

### **7.1 KOZI Pellet Insert Additional Requirements**

When installing and removing a **KOZI** pellet insert in a masonry or listed factory built fireplace, the following requirements must be met:

1. The room in which the insert is installed must be sealed from the exterior. This can be done by sealing the chimney cavity to the venting either at the terminal (see figure 12A) or at the chimney damper (see figure 12B).
2. When installing the insert and its surround into a masonry or listed factory built fireplace, the air flow of the existing fireplace must not be altered. Make sure no louvers, cooling air or outlet ports are blocked.
3. When installing an insert, a full height listed chimney liner must be attached to both the insert flue collar and to the chimney top as shown in figure 12A or a partial chimney liner may be attached to the insert flue collar and extending a minimum of 6 inches into the chimney cavity as shown in figure 12B. The chimney liner must be properly sealed to the seal plate using high temperature (RTV) silicone. This chimney liner must be stainless steel.
4. A permanent metal tag must be attached to the back of the fireplace. The metal tag will state the following “After removal of this pellet insert, the fireplace must be restored to its original state for safe use”.
5. The fireplace can NOT be altered in any way except for the following situations:
  - A. For installation of a chimney liner, the chimney damper may be removed.
  - B. External trim pieces of a fireplace can be removed only if they do not affect the operation of the fireplace upon removal and they can be reassembled when the insert is removed.

- C. Where a L or PL type venting is used to vent the insert through a masonry fireplace (see “Typical installation Configurations” section, figure 10A), a hole may be cut through the fireplace to accommodate the vent pipe. This hole must be properly repaired upon removal of the insert.

### 7.2 Surround Assembly

The **KOZI** pellet insert surround can be seen in Figure 14. The surround comes in 3 separate pieces and needs to be assembled before being attached to the heater. Layout the top and sides of the surround on the floor as shown in figure 14. Verify that each side piece mounting holes are aligned with the top piece mounting holes. Using the supplied 1/4” bolts, secure the side pieces to the top. Your surround is now ready to mount to the insert.

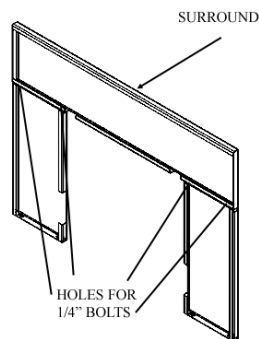

Figure 14. **KOZI** pellet insert surround

### 7.3 KOZI Pellet Insert Installation

Please follow the following steps when installing a KOZI pellet insert:

1. Verify that the fireplace opening meets the insert’s minimum requirements.

Working from the exterior of the building:

2. Attach and seal the exhaust venting to the terminal using sheet metal screws and high temperature (RTV) silicone sealant.
3. Insert the venting into the existing chimney and secure the terminal to the chimney. Ensure that the venting and chimney are properly sealed.
4. If outside combustion air is being used, install the air intake as necessary.

Working from the interior of the building:

5. Verify that an electrical outlet is available for the pellet insert. If not, have one installed.
6. Place the insert part way into the opening.
7. Attach and seal the free end of the exhaust venting to the pellet insert using sheet metal screws and high temperature (RTV) silicone sealant.
8. If the top of the chimney was not sealed to the vent terminal in step 3, seal the existing chimney damper to the new pellet venting to prevent drafts to and from the home.
9. Plug the power cord into the electrical outlet.
10. Assemble the surround (if not previously assembled) and slide it on the insert (see the “Surround Assembly” section).
11. Push the insert into the cavity until the surround touches the existing fireplace.



## 7.4 KOZI Pellet Insert Removal

There may be some situations where the **KOZI** pellet insert needs to be removed from the fireplace; venting may need to be resealed, regular maintenance performed, etc.... Removal of the **KOZI** pellet insert heater from a fireplace is the reverse of installation with the following exceptions: make sure the insert is not operating, has had sufficient time to cool down and that power to the insert has been removed. Now you can pull the insert all the way out and do the maintenance on the insert or fireplace.

## 7.5 Operation and Maintenance

Please refer to the “Heater Operation” section of this manual for complete instructions on how to operate your **KOZI** pellet insert. Please note that fuel loading on the insert is done through the small opening on the top of the stove. To load fuel into the insert, remove the cover plate from the top of the insert, pour fuel into the opening and replace the cover plate. **DO NOT** place hands inside the opening to the hopper. There are moving parts in the hopper which can cause bodily harm.

Maintaining the **KOZI** pellet insert is the same as maintaining a free standing pellet stove. Please read the “Maintenance” section for instructions on cleaning your insert, venting and other maintenance precautions.

## 8. Mobile Home Additional Installation Requirements

### 8.1 Typical Mobile Home Installation Configuration

The following figures describe some typical installations for mobile homes. Variations of these are possible. Common sense, safety and compliance with local building codes must be respected in any variation.

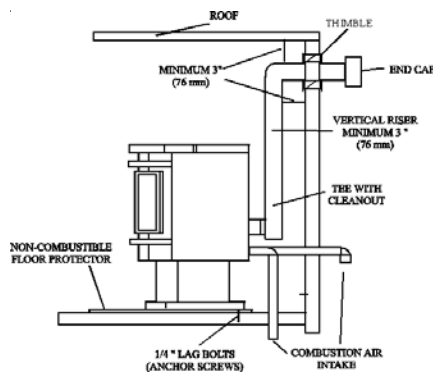

Figure 15A. Mobile home installation through wall; interior rise

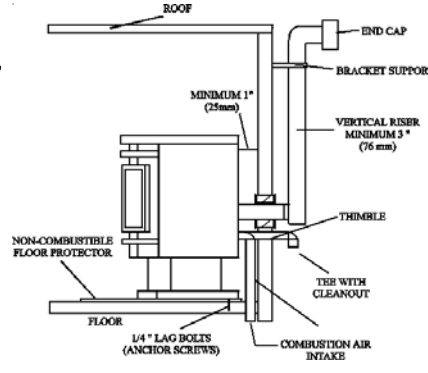

Figure 15B. Mobile home installation through wall; exterior rise

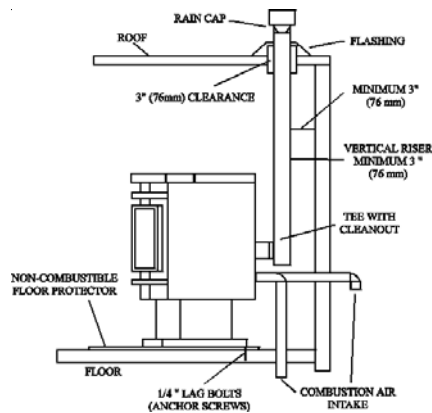
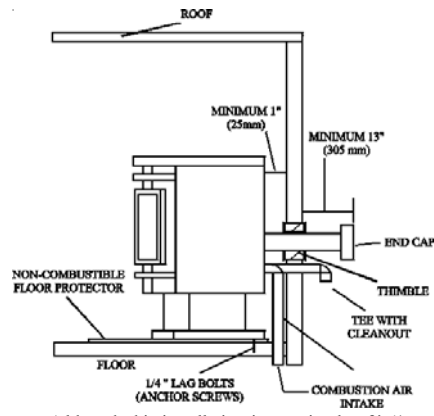

Figure 15C. Mobile home installation through roof



(although this installation is permitted, a 3' (1 m) vertical rise is strongly recommended)

Figure 15D. Mobile home installation through wall

## 8.2 Recommendations for Mobile Home Installation

1. Make sure there is an effective vapor barrier where the venting penetrates to the outside of the mobile home. Seal all openings in the vapor barrier as required.
2. Make sure the mobile home has adequate ventilation. Your stove is a solid fuel burning appliance. As such, there is a possibility of smoke entering the room. By making sure the mobile home is adequately vented, you reduce the chances of smoke remaining in the mobile home.
3. Make sure the venting is properly installed and sealed. Leaking vent pipes may set off smoke detectors in the mobile home. Also, some fuels may produce carbon monoxide which, in large amounts, can be fatal. Make sure the venting is installed properly to prevent leakage of carbon monoxide into the mobile home.
4. If parts become damaged or need to be replaced, please contact your local dealer or visit [WWW.KOZISTOVES.COM](http://WWW.KOZISTOVES.COM). Do NOT replace parts with any other parts not specified by your local dealer or manufacturer.

## 8.3 Mobile Home Combustion Air Intake Requirements

All mobile home installations MUST use combustion air from the outside. This heater must be connected to the exterior of the mobile home using a noncombustible metal pipe, with a minimum 2 inch (50 mm) diameter. APR Industries Ltd. part # AK100 (Air Intake Kit) can be used for this purpose. Use of plastic pipes are not permitted. Please read the "Combustion Air Intake Requirements" section for more information.

## 8.4 Exhaust Vent Requirements

Venting a **KOZI** pellet burner for a mobile home is similar to that of a conventional home. Please refer to the “Typical Mobile Home Installation Configuration” section for typical venting configurations the “Venting System” for vent termination and other requirements. It is highly recommended that 3 ft. minimum of vertical venting be used (as shown in Figure 15A and Figure 15B). This will reduce the chance of smoke spillage into the mobile home in case of a power failure.

## 8.5 Other Mobile Home Installation Requirements

1. The heater must be securely anchored to the floor of the mobile home. There are 2 holes located on the base of the stove near the back (4 on KSH models). Use two 1/4” lag bolts (not supplied) in these holes to anchor the stove to the floor of the mobile home. For KSH models, the side panels will need to be opened to access these holes.



Figure 16A BayWin  
Anchor Holes

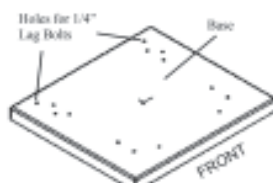

Figure 16B Model 100  
Anchor Holes



Figure 16C KSH  
Anchor Holes

2. There must be a noncombustible floor protector placed underneath the heater and extending a minimum of 6” (150 mm) in front of the heater (see “Clearance to Combustibles” section for more information).
3. This heater can not be installed in any sleeping room of the mobile home.
4. The heater must be grounded to the steel chassis of the mobile home (unless this is not required by local code).
5. The installation must be in accordance with the Manufactured Home and Safety Standard (HUD), CFR 3280, Part 24

**WARNING: DO NOT INSTALL IN A BEDROOM OF A MOBILE HOME**

**CAUTION: THE STRUCTURAL INTEGRITY OF THE FLOOR, WALL AND ROOF OF THE MOBILE HOME MUST BE MAINTAINED.**

### **III. OPERATION**

#### **1. General overview**

The first step in understanding your new **KOZI** heater is to familiarize yourself with its operation. Your heater has 3 main systems: Feed, Combustion and Circulation. These 3 systems work together to produce enough heat for your room. The feed system uses an auger to “feed” the pellet fuel into the burn pot. The combustion system provides the air for the fuel to burn and pushes the “smoke” outside through the vent pipes. The circulation system takes cold air from the room and pushes it through the heat exchanger where it will warm up and flow back into the room as hot air. These 3 main systems are all control by the *MX2*<sup>TM</sup> control system (see Figure 17). The *MX2*<sup>TM</sup> control system will be described in more detail later.



Figure 17.  
*MX2*<sup>TM</sup> control

#### **2. Safety features**

1. Pressure switch: This safety device is used to turn the feed off if pressure is lost in the stove.

Please note that if your door is open or your ash gates/tray are not properly sealed, your pellet heater will not feed

2. Circulation fan override: If your pellet heater begins to overheat, this safety device switches the circulation fan to the highest possible setting to try to cool your heater down to a safe temperature.
3. High limit/manual reset thermal disk: If the Circulation fan override fails to cool the heater down fast enough, this thermal disk will turn the feed off. This final safety device guards against your heater overheating. If this thermal disk trips, the right side panel will need to be opened and the thermal disk reset. See “Maintenance” and “Troubleshooting” sections for more information.
4. Hopper lid switch: This safety device stops the auger from turning when the hopper lid is opened, preventing any bodily harm.

#### **3. Electric Igniter**

Some models of **KOZI** pellet heaters are factory equipped with an electric igniter. On all other models, the electric igniter is optional and can be purchased/installed at any time. The electric igniter is a convenient way of lighting the fire in your heater without the use of lighter gels or starter fuels. Ask your dealer if an electric igniter is right for you.

#### **4. *MX2*<sup>TM</sup> Control**

##### **4.1 Basic Description**

The *MX2*<sup>TM</sup> control is a digital control that uses a computer to control the operation of your heater. You should be familiar with all of the buttons on this control before using your heater. Each button and their function are described here.

##### **4.2 “AUTO,HIGH/LOW,MANUAL” Switch**

Your pellet heater is capable of operating in 3 different modes; “AUTO”, “HIGH/LOW” and “MANUAL”. Figure 18 will help you determine which mode is suitable for use in  
Page 20

your home. More information on each of the modes is provided later.

Mode Selection Guide			
Switch Position	Igniter Required	Thermostat Required	Description
AUTO*	Yes	Yes	Turns Heater ON and OFF based on wall thermostat, remote control, wall switch or other switching device.
HIGH/LOW	Optional	Yes	Switches heater from user setting to factory LOW setting based on wall thermostat, remote control, wall switch or other switching device.
MANUAL	Optional	No	Relies on a person to press the ON/OFF button located on the control panel. Will automatically light if equipped with electric igniter.
* CAUTION: May result in shortened igniter life. See complete mode description.			

Figure 18, Mode selection.

- a. “AUTO” Mode: With the switch in this position, your heater will turn itself on and off based on an externally wired switch. The most common use of this mode is with a wall thermostat. When wired to a wall thermostat, the heater will automatically light itself when the room temperature falls below the thermostat setting and will automatically turn itself off when the temperature reaches the thermostat setting. This mode can also be used with a wall switch or remote controls. Consult your local dealer or visit [WWW.KOZISTOVES.COM](http://WWW.KOZISTOVES.COM) for more information on available options.

Please note that “AUTO” mode, when used in conjunction with a wall thermostat, can result in “reduced” igniter life. Always use your stove on the lowest possible heat setting when in this mode. This will help reduce the number of ignition cycles and will help prevent premature igniter failure.

- b. “HIGH/LOW” Mode: With the switch in this position, your heater will alternate from a factory preset low to the setting you have chosen with the “HEAT SELECT” button (see {“HEAT SELECT: Button”} section for more information). This mode is almost exclusively used with a wall thermostat and is highly recommended since it can create substantial fuel savings. This mode does not need an electric igniter. If an electric igniter is installed, the heater will automatically light itself when it is first turned on. If no electric igniter is installed, the fire will need to be lit manually (see “Starting (lighting) your Heater” section).
- c. “MANUAL” Mode: When used in this mode, your stove is controlled from the control panel only. Although an electric igniter can be used in this mode, it is not required. When the heater is the “MANUAL” mode, the heater will not respond to any external switch (Thermostat). If an electric igniter is installed, the heater will automatically light itself when it is first turned on. If no electric igniter is installed, the fire will need to be lit manually (see “Starting (lighting) your Heater” section).

#### 4.3 “ON/OFF” Button

This button allows you to turn the stove on and off. Once pressed, the stove will go through a start-up sequence and the ON/OFF light will blink. During this time, the feed rate is preset and the “HEAT SELECT” button is disabled. Once the stove is warm enough, the “ON/OFF” light will stop blinking and you will be able to change the heat setting with the “HEAT SELECT” button as described next.

#### 4.4 “HEAT SELECT” Button & Bar Graph

There are 5 possible heat settings for your heater. Each setting is indicated in the bar graph; 1 being the lowest, 5 being the highest. Pressing the “HEAT SELECT” button will change the heat setting as indicated in the bar graph. Each time the button is pressed, your heater will go to the next higher heat level (from 1 to 2, 2 to 3 etc...). Once the heat level reaches the highest setting (5) and the “HEAT SELECT” button is pressed again, the heat level will return to the low setting (1).

Please note that during the start-up period, the “HEAT SELECT” button is disabled. At some point during the start-up period, you will be able to set the heat level but the heater will not operate at the desired setting until it has warmed up properly. Also, your heater will always remember which heat setting was used last and return to that setting next time the stove is turned on (Power failures will result in this setting being lost).

#### 4.5 “AUGER” Button

Your heater uses an auger system to feed fuel into the burn pot. When the auger system is working, the “AUGER” light will be on. During normal operation, this light should blink periodically. Holding the “AUGER” button will run the auger system continuously. This button should only be used to fill the auger with fuel. Using this button during normal operation will cause too much fuel to fall into the burn pot and may result in damage to the heater or an unsafe situation.

#### 4.6 “FAN” Button

During normal operation of your heater, the circulation fan (blows air into the room) speed can be changed by changing the heat setting (see “HEAT SELECT” button) or pressing the “FAN” button. The “FAN” button is used to override the factory fan setting and run the circulation fan on the highest setting. Pressing the “FAN” button again will slow the fan down. There are 5 settings in total for the fan speed. Once the fan is in the lowest setting, pressing the “FAN” button will bring the fan to the high setting. If you want to run the fan back to its original preset setting, first to press the “HEAT SELECT” button to change the setting. Now, press the “HEAT SELECT” button till you bring it back to the setting you want to run the stove at.

#### 4.7 “TRIM” Button

This button is used to compensate for fuel variations at the lowest heat level only. With the heater at the lowest heat level (1) pressing this button once will increase the feed rate to slightly above the normal low setting. At this “TRIM” setting, the (1) and (5) lights will be on. Pressing the “TRIM” button again will cause the feed rate to decrease slightly below the normal low setting. At this “TRIM” setting, the (1) and (4) lights will be on. Pressing the “TRIM” button again will return the feed rate to the normal low setting. At this “TRIM” setting, only the (1) light will be on.

#### 4.8 Wall thermostat, wall switch or other switching device.

The *MX2*<sup>TM</sup> control is capable of using an external switch (such as a millivolt wall thermostat) to turn the stove on and off. Any millivolt rated switching device can be used with this control. The switch/thermostat must be wired to the terminals as shown in Figure 19.

TO PREVENT INJURY OR DAMAGE TO THE HEATER, ALWAYS UNPLUG THE HEATER FROM THE POWER OUTLET BEFORE SERVICING.

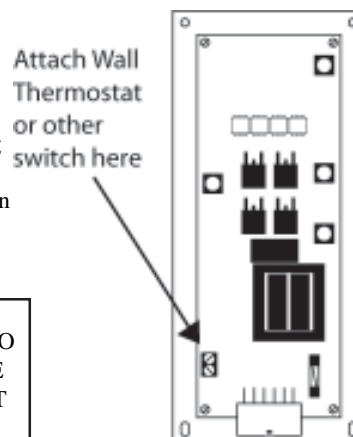

Figure 19. Wall thermostat terminals

#### 4.9 Damper Control

The damper control rod is located on the left side of the heater. This rod controls the amount of air passing through the burn pot. By pushing the control rod in, you reduce the amount of air passing through the burn pot. By pulling the rod out, you will increase the amount of air passing through the burn pot. Once properly set, you should not need to adjust the damper. The *MX2*<sup>TM</sup> control will automatically change the exhaust fan speed to adjust the amount of combustion air needed for each heat setting. A typical damper setting is between 5/8" (15 mm) to 3/4" (20 mm) from the fully pushed in position.

#### 4.10 Starting (lighting) your Heater for the First Time

Read the following instruction completely before attempting to light your heater for the first time. This method applies to all modes of operation ("AUTO, HIGH/LOW, "MANUAL"). For "AUTO" mode, use thermostat or other switching device in lieu of "ON/OFF" button..

Once your heater is properly installed, complete the following steps to light it for the first time or whenever your heater runs out of fuel:

1. Fill the hopper with pellet fuel. At this time the auger tube is empty. It needs to be filled before the heater can be operated properly.
2. Press the "ON/OFF" button; The "ON/OFF" light and the "AUGER" light should begin to blink. The motors should also begin to turn.
3. Press and hold the "AUGER" button; the "AUGER" light should light and stay lit until the button is released.
4. Continue to hold the "AUGER" button until fuel begins to drop into the burn pot (located inside the burn chamber, see "Stove Cross Section" diagram for exact location). This may take several minutes. If the heater turns OFF before fuel begins to drop into the burn pot, repeat steps 2, 3 and 4.
5. Release the "AUGER" button once pellet fuel begins to drop. If your heater IS NOT equipped with an electric start; allow the heater to stop (this may take up to 20 minutes) and proceed to "Starting (lighting) your Heater" section. If your heater IS equipped with an electric start;

proceed to step 6.

6. Monitor the burn pot. A flame should appear within 5 to 8 minutes. Allow the flame to stabilize. **IN THE EVENT YOUR HEATER SHUTS OFF BEFORE THE FLAME IS STABLE** or if a flame does not appear; press the "ON/OFF" button once again Refer to the "Adjusting your Heater" section for more information on operating your heater properly.

#### 4.11 Starting (lighting) your Heater

To start your heater, complete the follow steps:

1. Ensure there is adequate fuel in the hopper and that all ashgates and doors are closed. Open ashgates/door will turn OFF the feed system.
2. Adjust damper to approximate setting. (If in doubt, pull open to approximately 3/4" - 2 cm)
3. If your heater is equipped with an electric igniter, proceed to step 8. In the event that your electric igniter should fail, proceed to step 4.
4. Open the burn chamber door and place a handful of fuel in the burn pot. The burn pot should be approximately 1/4 full with wood pellets.
5. Pour lighter gel on pellets in the burn pot.

**DO NOT USE CHEMICALS OR FLUIDS TO START THE FIRE. USE ONLY PROPER LIGHTER GEL.**

6. Ignite lighter gel with a barbecue lighter and allow the pellets to catch fire. **DO NOT ATTEMPT TO IGNITE HOPPER FUEL ON FIRE.**
7. Close the combustion chamber door.
8. Press the "ON/OFF" button. The following should happen :
  - a. The exhaust fan will start.
  - b. The circulation fan will remain off.
  - c. The feed system begins to feed. The "AUGER" and ON/OFF" lights will begin to blink.
  - d. If an electric igniter is installed, it will come ON.
  - e. On electric start models, the flame should appear within 5 to 10 minutes.
10. Allow the flame to stabilize for 15 minutes.
11. Adjust the heat setting and damper as necessary. (See "Adjusting your Heater" section)
12. If the heater shuts OFF during the start up cycle and there is still a flame, press the start button again.

**WARNING: Make sure the amount of fuel in the burn pot does not exceed the height of the burn pot at any point during operation. This can cause severe damage to your heater.**

**DO NOT BURN GARBAGE OR FLAMMABLE FLUIDS SUCH AS GASOLINE, NAPHTHA OR ENGINE OIL.**

**HOT WHILE IN OPERATION. KEEP CHILDREN, CLOTHING AND FURNITURE AWAY. CONTACT MAY CAUSE SKIN BURNS.**



#### 4.12 Stopping your Heater

To stop your heater, simply press the “ON/OFF” button (for “AUTO” mode, switch the thermostat or other switching device to “OFF”). This will cause the feed system to stop (the “AUGER” light will stop blinking) and the flame should die out within 5 minutes. The exhaust fan and circulation fan will continue to run until you heater is cold (approximately 30 minutes). DO NOT turn OFF electrical power to stop the heater, as this will result in your heater overheating and may damage the control.

#### 4.13 Adjusting your Heater

The heater will not work properly if the ash door or the glass door are not properly closed OR if the wrong size of venting is used. It is equally important that you use good quality, wood pellet fuel. Poor fuel will create a poor burn, excessive ash and will plug the burn pot. Refer to the “Fuel Requirements” section for more information on fuel quality.

To increase the heat output of your heater, simply press the “HEAT SELECT” button. In a few minutes the flame size will increase. If the flames are darkish with black tips, open the exhaust damper slightly and allow the flame to stabilize. Repeat the procedure if more heat is desired. Flames that are too large mean the feed rate is too high for the amount of combustion air present. Increase the amount of combustion air by pulling the damper out slightly. In few minutes the size of the flame will reduce. If the size of the flame is fluctuating between feed drops, this indicates the amount of combustion air is too much for the amount of feed. In this case, close the air damper slightly and once again, allow the flame to stabilize. If the air damper is open too far, there is a chance of extinguishing the fire. Some fuels have a tendency to leave ash and clinker deposits in the bottom of the burn pot.

### **IV. MAINTENANCE & CLEANING**

*Formation and Removal of Soot and Flyash* - During normal operation, your heater produces a lot of flyash. This flyash will collect in the vent pipes and inside your pellet heater and restricts the flow of the flue gases. Incomplete combustion occurs during start-up, shutdown, and incorrect operation of your pellet heater. Incomplete combustion creates soot which will also collect in the vent pipes and within the pellet heater. The soot and flyash deposits in your heater and venting system is harmful to the performance of your heater. Improper maintenance leads to poor performance, component failure and can be dangerous. Please adhere to the following maintenance schedule :

Do not use abrasive chemicals to clean the heater and/or labels placed on the heater. These chemicals can damage both the paint and labels on the heater.

ALLOW THE HEATER TO COOL TO ROOM TEMPERATURE AND UNPLUG THE HEATER BEFORE PERFORMING ANY MAINTENANCE.

Before each heating season:

1. Clean the venting system. It is imperative that you check the venting

is a significant blockage of air or fuel, it should be cleaned out. To prevent the risk of a chimney fire. By making sure the exhaust venting system and the heater itself are being maintained properly and are cleaned on a regular basis, you reduce the likelihood of a chimney fire occurring. Please contact your local building or fire officials in your area for information on how to handle a chimney fire. Have a plan of action ready in case of a chimney fire occurs.

2. Clean behind the back heat shield as well as all exhaust passages. Ashes can build up behind the back heat shield and inside the exhaust passages. To remove the back heat shield you must remove 4 bolts located at each corner of the heat shield. On some models the side heat shields must first be removed by removing the 2 bolts holding them in place. Using a brush, remove all of the ashes that have built up on the back wall of the combustion chamber, on the inside of the heat shield as well as in the exhaust passage. Inspect the auger chute gasket at this time. Make sure the gasket is still in good condition and that it is in the original position when the back heat shield is bolted back into position. Make sure to clean behind the back heat shield after every 3 tons of fuel burned. See Figure 20 and Figure 21 for removal of the heat shields.

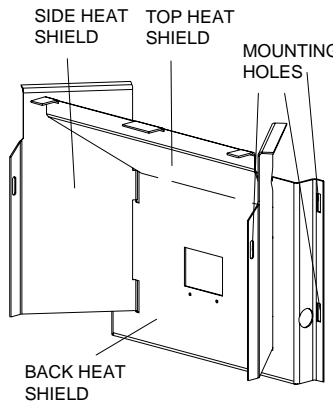

Figure 20. Model 100 and KSH 120 Heat Shields.

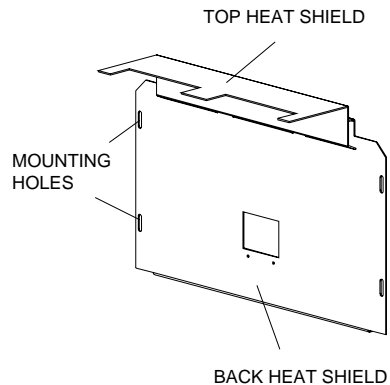

Figure 21. BayWin Heat Shields.

3. Clean the exhaust fan and housing. Ash accumulation on the fan blades will reduce the life of your exhaust fan. Frequent cleaning will help extend the life of this component. Open the left side panel to access the exhaust fan. Using a Common (flat head) screw driver, remove the 6 sheet metal screws holding the fan motor to the housing (See Figure 22). Using a brush, clean all ash from the exhaust fan blades and housing.

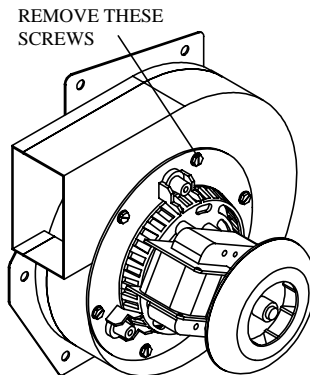

Figure 22. Exhaust fan assembly.

4. Inspect the condition of the door gasket periodically and replace it as necessary. It is important to make sure the door gaskets are in good condition. Gaskets in poor condition will not allow the door to seal properly and the heater will not function as efficiently.
  
5. Oil the circulation fan motor. To oil the motor bearings, the right hand side panel must first be opened. This is done by removing the 2 screws near the front of the stove as shown in Figure 23. Use a Robertson (square head) or Common (flat head) screwdriver to remove the screws. You will now be able to swing the panel open and access the circulation fan. There are 2 oil ports located on the top of the motor, one near the end and one near the fan housing as shown in Figure 24. There may be rubber plugs in one or both of these oil ports. These plugs must be removed prior to and replaced after oiling. Place a few drops of light oil, such as sewing machine oil, in each port.

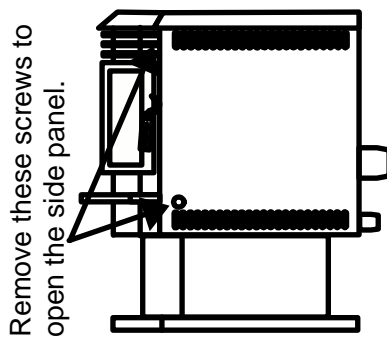

Figure 23. Holes for screws on the right side panel



Figure 24. Oil ports on a circulation fan

6. Perform weekly maintenance.

Weekly or more frequently if needed:

1. Pull and push the cleaning rod which is located in the center, above the door (See Figure 25). This will remove the ash deposits on the heat

exchanger tubes. The removed ash will fall on the top heat shield, located in the burn chamber.

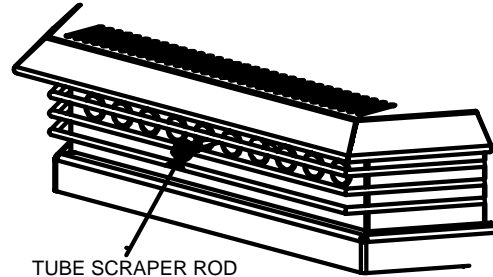

Figure 25. Tube scraper rod to clean the heat exchanger pipes.

2. Lift the top heat shield. Remove it carefully as there may be a significant amount of ash on it. Dump the ashes into the burn chamber.
3. Using a brush, clean the top heat shield and remove it from the heater.
4. Remove the burn pot, burn pot stand and splash guard (Figure 26) and clean them thoroughly. Lift the burn pot and splash guard to remove. Lift up on the burn pot stand and pull towards you to remove. Make sure there are no ashes remaining in the burn pot stand and that all the holes in the burn pot are clear. Failure to do so can be a fire hazard. Place all ashes into a metal container with a tight fitting lid.

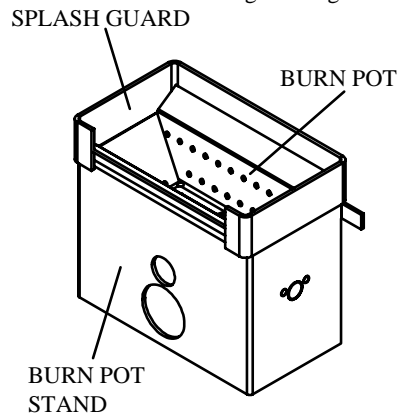

Figure 26. Burn pot stand assembly.

5. Using the brush, clean the walls and floor of the burn chamber.
6. If your unit is equipped with the large ashtray, open the ashtray slightly and pull on each ash gate (Figure 27) until the ash falls from the burn chamber into the ashtray. Do not pull the ash gates too far as they may fall out. Sweep remaining ashes into the ashtray. For models equipped with the small ashtray (KSH series & Model 100 Insert) turn the 2 coil

handles counter-clockwise to release the latch mechanism and pull the ashtray out. For models with no ashtray, scoop out the ashes into a metal container with a tight fitting lid. An alternate method to cleaning the ashes in the burn chamber area is to purchase a pellet vacuum. These vacuums are specifically designed for the removal of ashes in a pellet stove.

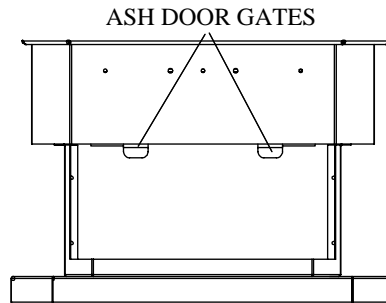

Figure 27. Ash gates for a **KOZI** pellet stove.

7. Close the ash gates (if equipped) and remove the ashtray. Dispose of the ashes in a safe manner. If the ashes are stored in a container, make sure the lid is secure. **DO NOT** place the container on a combustible surface. Replacement of ashtray is reverse of removal.

*Disposal of Ashes* - Ashes should be placed in a metal container with a tight fitting lid. The closed container of ashes should be placed on a noncombustible floor or on the ground, well away from all combustible materials, pending final disposal. If the ashes are disposed of by burial in soil or otherwise locally dispersed, they should be retained in the closed container until all cinders have been thoroughly cooled. Do not place any other waste materials in this container.

8. Empty out the hopper once every 2 weeks. Vacuum all the sawdust build up in the hopper and auger chute opening. Cleaning out the sawdust from the hopper will help prevent a hopper fire from occurring.
9. Reinstall all removed parts in their original positions.
10. Clean the glass with a mild glass cleaner when dirty. **DO NOT** clean the glass when the door is hot. Cleaning the glass will allow you to see the flame and how it is burning. This is very important to see if the heater is burning properly or not. **DO NOT** hit the glass or slam the door shut. This may cause the glass to crack or break. **DO NOT** operate the heater if the glass is cracked or broken. **DO NOT** replace the glass with any type of glass other than an APR Industries Ltd. factory approved glass. If the glass cracks or breaks, turn the heater **OFF**. **DO NOT** operate the heater until the glass has been replaced.

**NOTE:** Depending on the type of fuel you use and the frequency that you use the pellet stove, you may need to clean the stove more frequently.

After each heating season:

1. Remove all the pellet fuel from the hopper. Run the heater to empty the auger tube. Vacuum the hopper and auger tube. Clean the rest of the heater.
2. Open up both side panels. Clean out any pellets, dust, ashes or debris that may have built up in the back of the pellet stove.

## **V. TROUBLE SHOOTING GUIDE**

### **1. Trouble Shooting**

Your **KØZI** pellet heater is equipped with a diagnostic light feature. When a problem occurs, the heat setting bar graph will light up to indicate where the problem may be. Each light has been numbered for easy identification. The chart below has been included to help you determine which corrective action should be taken. A complete description of each corrective action is included in the following pages of this manual. Some problems, such as flame problems, will not cause the diagnostic lights to light up.

<i>MX2</i> Control Trouble Shooting Guide				
Problem	Light Status	Possible Causes	Remedy	
Heater will not feed pellets.	All lights off	No power.	Check to see if heater is plugged in.	
			Check electrical outlet for power.	
	#2 light blinks (Pressure system failure)	Exhaust vent and exhaust fan are plugged	Clean exhaust venting and exhaust fan.	
			Exhaust passage and exhaust box pressure tap are plugged.	Clean exhaust passage and pressure tap.
			Pressure switch tube is cracked or broken.	Replace pressure switch tube.
			Pressure switch has failed.	Replace pressure switch.
			Exhaust fan has failed.	Replace exhaust fan.
	#3 light blinks (Proof of flame failure)	Hopper is empty.	Fill hopper with fuel.	
			Exhaust fan thermal disk has failed.	Replace exhaust fan thermal disk.
			Auger jam.	Empty hopper and clean out auger.
Auger motor has failed.			Replace auger motor.	
#4 light blinks	Manual reset thermal disk has failed.	Replace manual reset thermal disk.		
Stove won't turn off.	Normal	Exhaust fan thermal disk has failed.	Replace exhaust fan thermal disk.	
		Stove in "Cool Down" mode.	Allow sufficient time for the stove to cool down.	
		<i>MX2</i> Control board has failed.	Replace <i>MX2</i> Control Board.	
Stove will not light.	Normal	No pellet fuel.	Add fuel to the hopper.	
		Burn pot dirty.	Clean burn pot.	
		Fuse blown.	Replace fuse.	
		Igniter slipped out of igniter tube.	Push igniter back into place.	
		Igniter has failed.	Replace igniter.	
		No power to igniter.	Replace <i>MX2</i> Control Board.	
Fuel piles up.	Normal	Burn pot dirty.	Clean burn pot.	
		Poor quality fuel.	Change fuel supplier.	
Short flame on high feed.		Poor quality fuel.	Change fuel supplier.	
		Heat exchanger requires cleaning.	Clean heat exchanger.	
Too large and dark orange flame.		Poor quality fuel.	Change fuel supplier.	
Smell of smoke in room.	Normal	The pellet venting joints not sealed properly.	Seal all joints with high temperature RTV silicone sealant.	

## **2. Corrective Actions**

**BEFORE PERFORMING ANY SERVICE, MAKE SURE THE HEATER IS COLD AND UNPLUGGED.** We strongly recommend using qualified service people.

### **2.1 Proof Of Flame Failure**

- a. Verify that there is sufficient fuel in the hopper and that the heater has run for long enough to fill the auger tube. (See “Starting (lighting) your Heater for the First Time” section)
- b. Verify that the auger has not jammed. Occasionally, fuel can become lodged in the auger and prevent the augers proper operation. Open one of the side panels and grasp the auger motor. Move the auger motor back and forth. It may be difficult to move at first but should move relatively freely. If it will not move, empty the hopper and look for foreign objects in the auger.
- c. Verify that the auger motor is working. Plug the heater in. Without lighting a fire, start the heater. Verify that the white plastic fan on the auger motor is turning. If it does not turn, check for power at the auger motor and replace the auger motor as necessary. Remember to unplug the heater before attempting any service.
- d. Verify that the auger is properly secured to the motor. Empty the hopper and locate the auger bolt (approximately 1/4” square heat) on the auger. Remove the bolt and make sure the hole is aligned with the flat portion of the auger motor shaft. Reinstall the bolt and tighten.
- e. If none of the above resolve your problem, contact your local KOZI dealer.

### **2.2 Pressure Switch Failure**

- a. Verify that the heater is clean. Clean all venting and exhaust passages in the stove. Refer to “Maintenance” section for more information on cleaning your heater.
- b. Verify that the pressure switch tube is not cracked or loose. Replace as required. Also verify that the pressure port on the stove is clean.
- c. Verify that the exhaust fan is in good working condition. On heaters equipped with the Standard control, turn the circulation fan off. Plug the heater in. Without lighting a fire, start the heater. You should hear the exhaust fan start and come to full speed relatively quickly. If the exhaust fan is not working or is slow to start, check for power at the exhaust fan and replace the exhaust fan as necessary. Remember to unplug the heater before attempting any service.
- d. Verify that the pressure switch is working properly. Apply a slight vacuum to the pressure switch tube. The pressure switch should “click”. Replace as necessary. Note: Pressure Switches rarely fail.
- e. If none of the above resolve your problem, contact your local KOZI dealer.

### 2.3 Manual Reset Thermal Disk Failure

This device is a safety device and should not be reset unless the cause of the problem is found and repaired. Typical causes are power failures while the heater is running and circulation fan failure.

- a. Verify that the circulation fan is in good working condition. Plug the heater in. Without lighting a fire, start the heater. You should feel a significant amount of air coming from the heat exchanger. If no air is felt, check for power at the circulation fan and replace the circulation fan as necessary. Remember to unplug the heater before attempting any service.
- b. Verify that the circulation fan thermal disk is working properly.
- c. Reset the Manual Reset Thermal Disk. Open the right side panel. Mounted on the back of the body of the stove you will see 2 thermal disks. One of these will have a red - reset button. Press the button to reset the thermal disk. When properly reset, the button should be loose.
- d. If your Manual Reset Thermal Disk is continuously tripping, contact your local KOZI dealer.

### 2.4 Ignition Failure

- a. Verify that your heater is equipped with an electric start. - Contact your seller.
- b. Verify that the fuse (if equipped) has not blown. The fuse is located in the equipment compartment on most models. Open the left side panel. You will find the fuse holder on the red wire. Replace the fuse as necessary.
- c. Verify for power at the igniter and replace the igniter as necessary.
- d. Verify that the burn pot is clean. See "Maintenance" section for more information on cleaning your heater.
- e. If none of the above resolve your problem, contact your local KOZI dealer.

### 2.5 Overheating

This problem occurs when the circulation fan setting is too low for the amount of heat generated.

- a. Verify that the circulation fan is working properly. With the heater plugged in, start the heater. Press the fan button. You should feel air coming from the heat exchanger. If not, check for power at the fan speed control and replace as necessary.
- b. If the heat is not needed, reduce the feed and damper accordingly. Continue to reduce the feed until the circulation fan does not run on high.
- c. If none of the above resolve your problem, contact your local KOZI dealer.

### 2.6 Lack of Air

The most common cause of flame problems are improperly sealed door and ashtrays, dirty heaters, poor fuel, improper installation and improper damper adjustment.

- a. Verify that all doors, ashtrays and ashgates are properly closed and sealed. Replace gaskets as necessary.
- b. Clean your heater thoroughly. Refer to the "Before each heating season:" portion of



the “Maintenance” section for detailed cleaning instructions.

- c. Adjust your heater properly. Refer to the “Adjusting your Heater” section for your control.
- d. Try using various brands of fuel. Although most manufacturers claim to produce “premium” grade wood pellets, contaminants and moisture will affect fuel quality.
- e. If your heater is less than one year old, your venting and/or air intake may be too restrictive. Contact your local KOZI dealer for venting recommendations.
- f. If your flames are dark orange, lazy, have black tips, or if the fuel piles up in the burn pot, increase the amount of air by pulling the damper rod out slightly.
- g. If none of the above resolve your problem, contact your local KOZI dealer.

#### 2.7 Excess air.

- a. If your flames are short, white, if your burn pot looks like a popcorn maker or your fire is always going out, push the damper rod in slightly. If this does not resolve your problem, contact your local KOZI dealer.

## VI. DIAGRAMS AND PARTS LIST

### 1. KOZI MX2™ Control Circuit Diagram

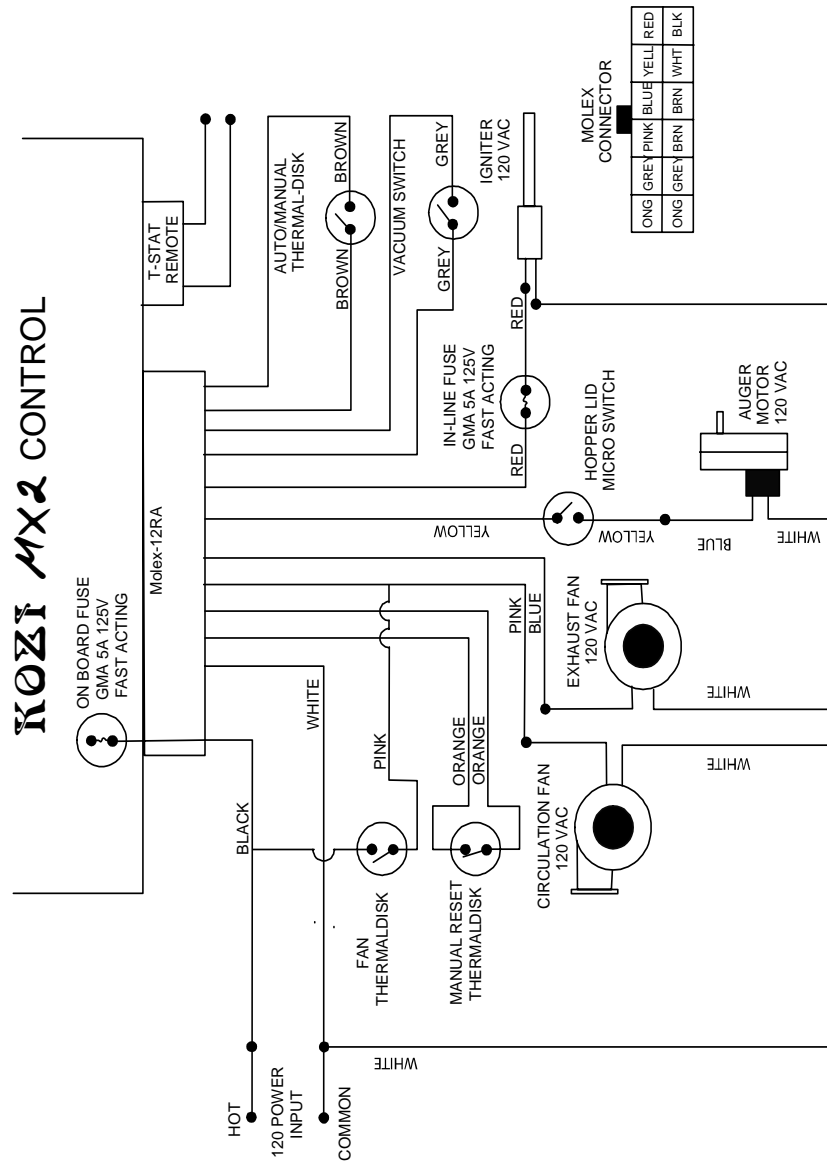

2. Stove Cross Section

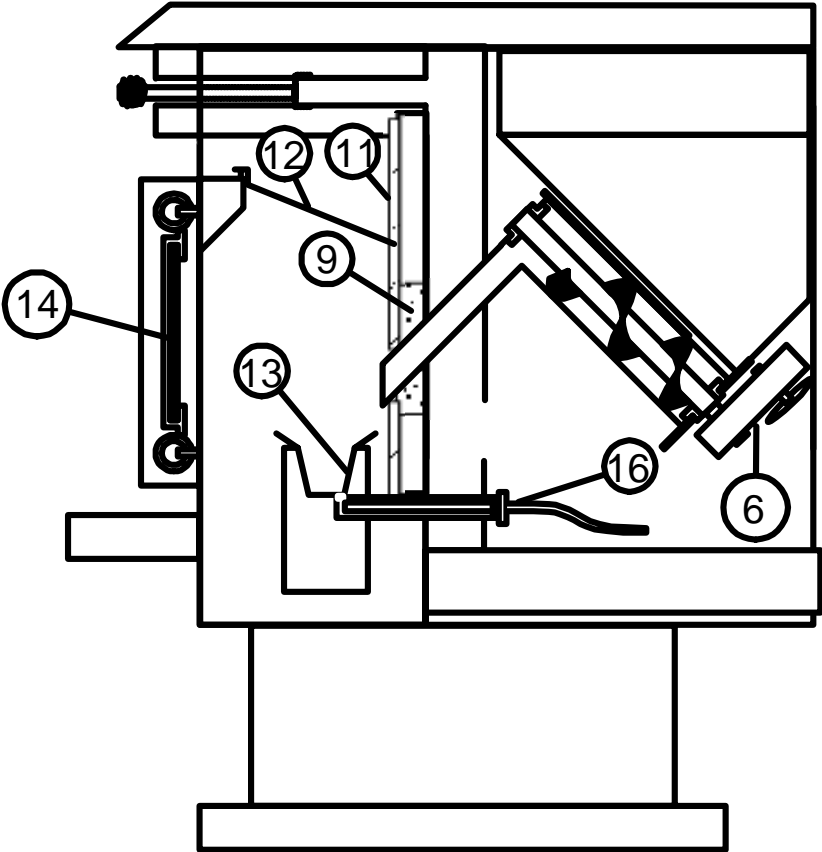

### 3. Equipment Compartment

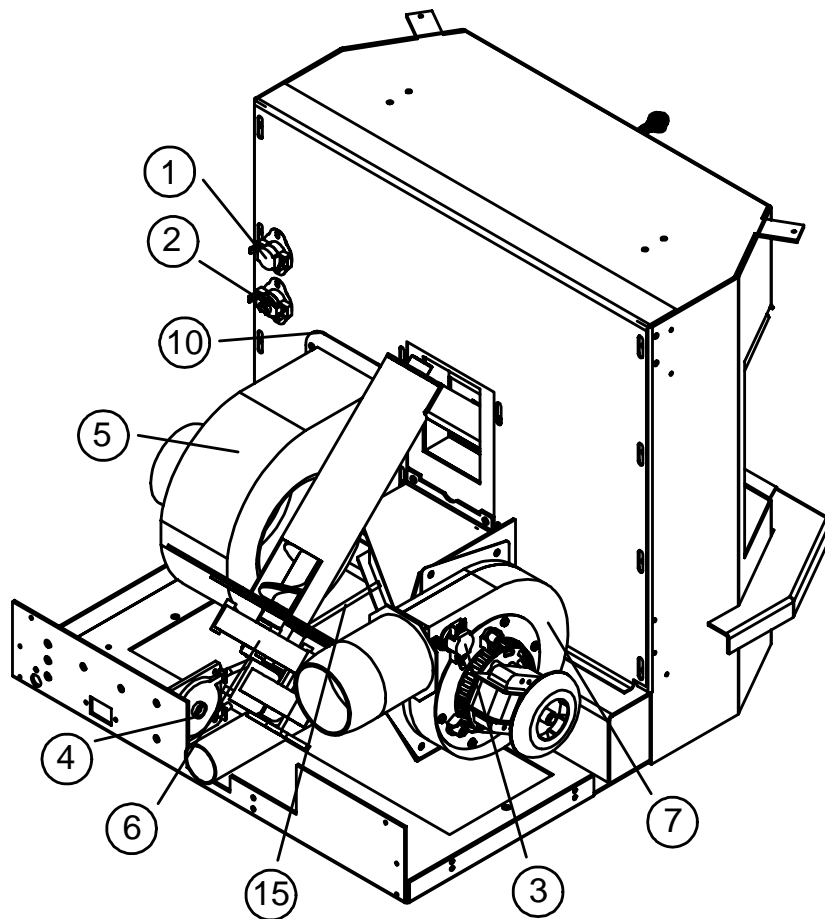

#### 4. Parts List

Item No.	Description	Part #
<b>Electrical Components</b>		
1	Circulation Fan Override, Thermal disk	TDKLMT04
2	Manual Reset, Overheat Thermal disk	TDKMR01
3	Exhaust Temperature Thermal disk.	TDKLMT01
4	Static Pressure Switch	SWC09902
5	Circulation Fan	FAN12001
6	Auger Motor	MTR12001
7	Exhaust Fan	FAN12003
8	MX™ Control Board	CBDKZ001
Not Shown	Hopper Lid Switch	SWC00109
<b>Gaskets &amp; Gasket Kits</b>		
Not Shown	Ash Tray Rope Gasket (Model 100 and KSH)	GKT00304
9	Auger Chute Gasket Kit	GKT9900
10	Circulation Fan Gasket	GKT00202
Not Shown	Glass Gasket Kit, BayWin (Includes inner and outer glass gasket)	GKTGLBW
Not Shown	Door Rope Gasket, Model 100 & KSH	DORRP100
Not Shown	Door Rope Gasket, Baywin	DORRPBW
Not Shown	Exhaust Fan Motor Mounting Gasket (Round)	GKT00208
Not Shown	Exhaust Fan Mounting Gasket (Polygon Shape)	GKT00209
<b>Heat Shields &amp; Other Parts</b>		
11	Back Heat Shield, Model 100 & KSH - Burn Chamber	BCKSL100
11	Back Heat Shield, BayWin - Burn Chamber	BCKSLBW2
Not Shown	Side Heat Shield Left, Model 100 & KSH - Burn Chamber	HTSL100
Not Shown	Side Heat Shield Right, Model 100 & KSH - Burn Chamber	HTSHR100
12	Top Heat Shield, BayWin - Burn Chamber	TPHSL0BW
12	Top Heat Shield, Model 100 & KSH - Burn Chamber	TPHSL100
13	Burner Pot	BPOT1005
14	Center Glass, BayWin	GLSCTBW
Not Shown	Side Glass, BayWin (1 only)	GLSSDBW
14	Door Glass, Small, Model 100 & KSH	GLS0SKSH
14	Door Glass, Large, Model 100 & KSH	GLS0LKSH
15	Static Pressure Switch Tube	TUBSPS01
16	Electric Igniter, Including Cartridge	EC2-HA-120
If you don't see the part you need, please contact your local KOZT dealer.		

#### VII. WARRANTY

APR Industries Ltd. honors a five-year limited warranty on all steel fabricated parts and a one-year warranty on all electrical parts. The following items are not covered under warranty:

Glass, Gasket and Seals, Ceramic Bricks, Burn Pot, Paint and Powder Coating, Gold Plating, Inner Heat Shields, Gear Motor, Self Igniter and Glass Saver™.

Contact Your Dealer for Warranty Information.

The limited warranty covers defects in the material and poor workmanship as long as the heater has been installed in accordance with the instruction manual. Warranty is null and void if the heater is misused. It is the option of APR Industries Ltd. whether to repair or replace the parts. The customer is responsible for all shipping costs to and from the factory.

**SERIAL NUMBER:** \_\_\_\_\_

**MODEL TYPE:** \_\_\_\_\_

**NOTES:** \_\_\_\_\_

\_\_\_\_\_

\_\_\_\_\_

\_\_\_\_\_

\_\_\_\_\_

\_\_\_\_\_

\_\_\_\_\_

\_\_\_\_\_

\_\_\_\_\_

\_\_\_\_\_

\_\_\_\_\_

\_\_\_\_\_

**WARRANTY REGISTRATION CARD**

**Customer:** Name: \_\_\_\_\_  
 Address: \_\_\_\_\_  
 Postal Code: \_\_\_\_\_ Country: \_\_\_\_\_  
 Phone Number: \_\_\_\_\_

**Product:** Type:  Stove  Insert  Fireplace  
 Model: **KOZI** \_\_\_\_\_  
 Serial Number: \_\_\_\_\_  
 Date Purchased: \_\_\_\_\_

**Dealer:** Name: \_\_\_\_\_  
 Address: \_\_\_\_\_  
 \_\_\_\_\_

**WARRANTY CARD / ONLINE REGISTRATION**

Please fill out the Warranty Registration Card and mail to the following address:

APR Industries Ltd  
 1354 Waverley Street  
 Winnipeg, MB  
 Canada, R3T 0P5

Make sure to attach a **COPY** of your proof of purchase along with the warranty registration card. Make sure to keep the original copy of your proof of purchase.

You can also register your pellet stove online at [www.kozistoves.com/warranty.php](http://www.kozistoves.com/warranty.php).

**[www.pelletstove.ca](http://www.pelletstove.ca)**